



CASE STUDY

Triflex

Delivering solutions together.

RESIDENTIAL STEP REFURBISHMENT
DUBLIN

SOCIAL HOUSING

Authorised Contractor:

May & Family Roofing

Area

20 sets of 15m²

Specifier:

Thorntons Chartered Building and
Valuation Surveyors

Systems

Triflex StairCoat Reinforced
Triflex ProDetail®

📞 01785 819119

🌐 triflex.co.uk

✉ info@triflex.co.uk

🌐 Triflex (UK) Ltd

🐦 @TriflexUK

Triflex (UK) Ltd. | Whitebridge Way | Stone | Staffordshire | ST15 8JS

Introduction

In this residential development, steps provide access to the property frontages. The precast concrete stair units were originally waterproofed with a thin layer of waterproofing furnished with terracotta tiles as overburden.



The challenge

Water ingress was evident between the pre-cast concrete stair units and the brick upstands at the sides of the stairs. The existing waterproofing was only apparent on the step structure, and not on the upstands. This was deemed to be poor and concerns were raised about the waterproofing durability for the areas that were waterproofed.

Action was required to ensure the stair structure was watertight for long term structural protection.

In addition, water was ponding on the external landings and some of the steps presenting a slip risk.





The solution

Following a Triflex site survey, a bespoke project specification was provided to Thorntons Chartered Building and Valuation Surveyors.

Triflex StairCoat Reinforced with quartz was proposed for the 20 sets of steps and landings complimented by Triflex ProDetail for the upstands.

For the preparation, the tiles were removed from the steps, and where present, any remnants of the existing waterproofing was removed by grinding. To address the issue of ponding water, Triflex ProFloor mortar was applied to the landing areas and some steps to create a fall across the depth of each step. The PMMA based system is specifically designed to act as a horizontal repair and leveling mortar for walkway, balcony and terrace systems. Whilst PMMA is hydrolysis resistant and will not degrade in ponding water, a repair was required for the safety of residents.

Triflex ProDetail is a certified reinforced cold liquid applied waterproofing membrane. It allows details to be waterproofed seamlessly and quickly. Here it was used for the upstands, providing a self terminating solution ensuring the continuity of waterproofing between the stairs and brick upstands. The Triflex StairCoat was then applied to the stairs and landing providing a reinforced, dynamic crack bridging solution that will protect the structure from the elements. The quartz finish provides an anti-skid surface, with a practical grey colourway chosen from the 50 UV stable colours available. The PMMA based systems are rainproof in just 30 minutes and cure in as little as 45 minutes. Thanks to the ultra-rapidly curing PMMA Triflex, disruption to residents was minimalised.

The stairs and landings are now waterproofed and protected with even surfaces and a pleasing aesthetic. The installation was carried out to a high standard by Triflex Authorised Contractor May & Family Roofing.

System benefits

Triflex StairCoat Reinforced

- Dynamic crack bridging, fully reinforced, cold applied system
- Fast curing with rapid installation
- Designed to overlay failed asphalt
- Rapid curing system - even at low temperatures
- Fully reinforced technology
- Solvent and isocyanate free
- Comes in a range of standard and bespoke colours

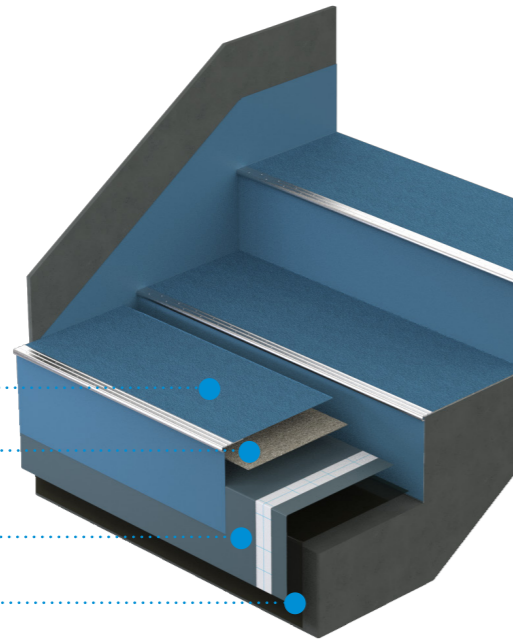

Finish

Surfacing layer

Reinforced waterproofing
(single process)

Primer

System benefits

Triflex ProDetail®

- Waterproof down to the smallest detail
- Compatible with virtually all substrates including asphalt
- Cold applied, fast curing with rapid installation
- Simple, single process waterproofing application
- Rapid curing system - even at low temperatures
- Fully reinforced technology
- Certified to the highest standards
- Designed for foot traffic and provides exceptional puncture resistance

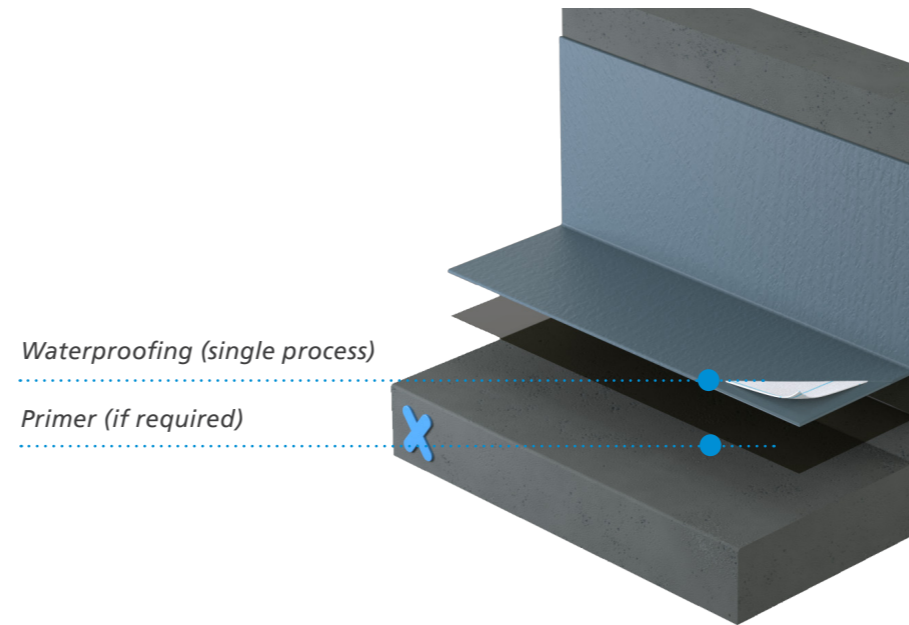

Waterproofing (single process)

Primer (if required)

Triflex

Delivering solutions together.

Triflex is the leading European specialist in cold liquid applied waterproofing, surfacing and marking resins. Our high-quality systems provide reliable and lasting waterproofing, surfacing, protection and markings for roofs, walkways, balconies, terraces, car parks, roads and infrastructure.

We are a family owned and operated company that provides tailored solutions worldwide. From our production facilities based in Minden, Germany, we have been researching and developing solutions designed to protect and repair the built environment for more than 40 years.

From our UK and Ireland headquarters based in Stone, Staffordshire we pride ourselves on providing our clients with tailored solutions and exceptional levels of service and support throughout all stages of their project. From conducting in-depth site surveys to our comprehensive testing and off-site and on-site support, we ensure that your project is completed expertly. Triflex solutions are certified to the highest standards and are backed up by long-term meaningful warranties, ensuring peace of mind for years to come.

☎ 01785 819119

🌐 triflex.co.uk

✉ info@triflex.co.uk

🌐 Triflex (UK) Ltd

🐦 @TriflexUK

Triflex (UK) Ltd. | Whitebridge Way | Stone | Staffordshire | ST15 8JS